

DreamCast Element 48



DEFINITELY CHIC

Warm up your days with this versatile firepit. Featuring ample table space for greater functionality.

Product Features/Specifications:

- 85K BTU or 165K BTU (Depending on model)
- Liquid Propane or Natural Gas
- Complimentary Lava Rocks
- Other media available for purchase
- Pilot Lit Ignition (available for upgrade to Electronic Ignition - please contact for further information)
- Weight: 374 lbs.
- Overhead clearance: None + 36" horizontally to combustibles.
- Not compatible w/portable Propane Systems
- Low clearance model available

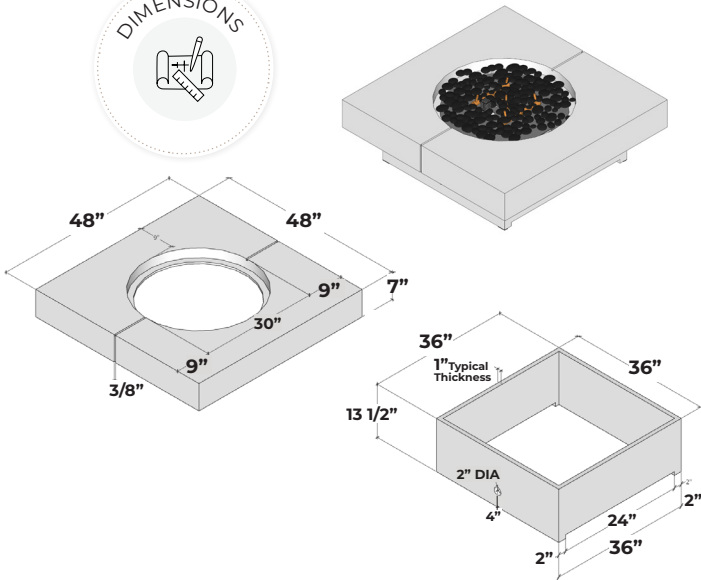
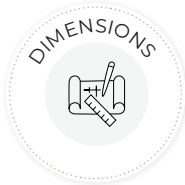

Min. and Max. Gas Inlet Pressures:

The installer is responsible for using the correct fuel lines and/or regulation to provide gas to the fire feature within the specified minimum and maximum gas inlet pressures.

Refer to installation manual for further information

Gas Inlet Pressures

Match Light	Minimum	Maximum
Natural Gas	7.0" W.C. (1.7436 Kpa)	10.0" W.C. (2.4884 Kpa)
Liquid Propane	11.0" W.C. (2.7399 Kpa)	13.0" W.C. (3.2381 Kpa)



DreamCast
Design & Production

Please contact us at **1-604-278-4939** with any questions.

We also encourage you to explore our website at www.dreamcastdesign.com

Our experienced team can assist you with product information, installation and design recommendations.

Element 48

DreamCast

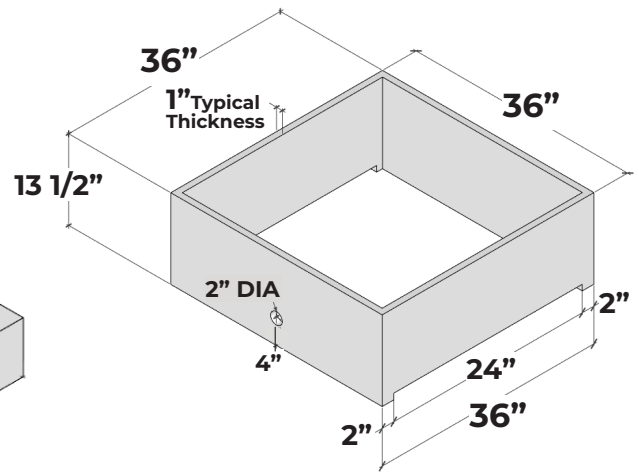
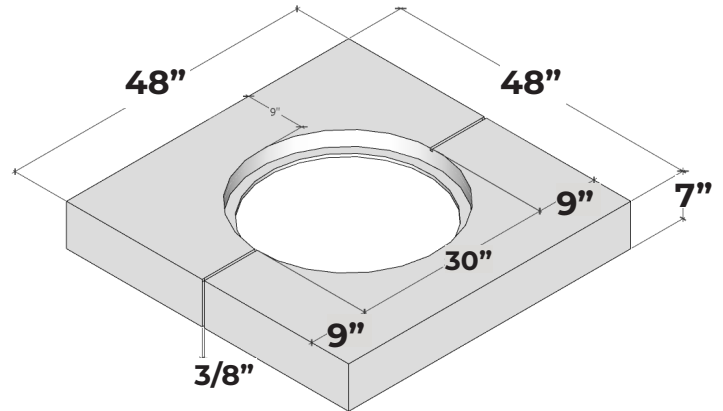
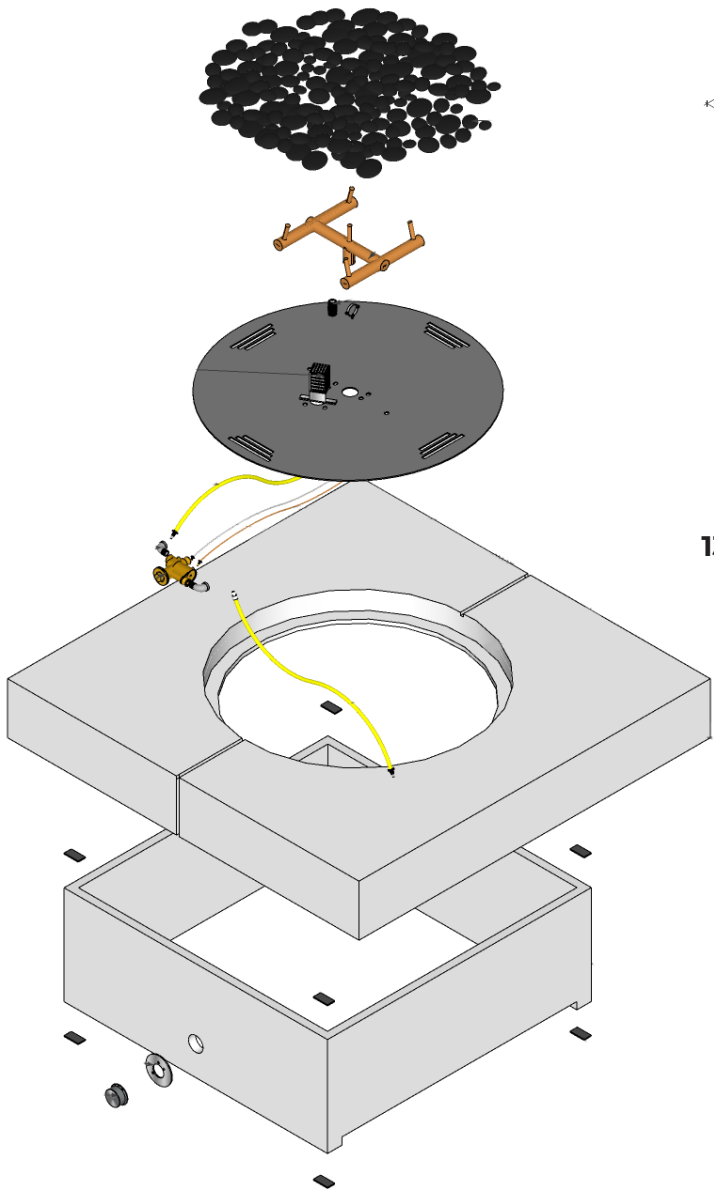

Versatile and dramatic the Element Firetable is a contemporary focal point. This fire table offers room for entertainment and is still compact enough to work in smaller spaces.

DreamCast
Design & Production

Please contact us at [1-604-278-4939](tel:1-604-278-4939) with any questions. We also encourage you to explore our website at www.dreamcastdesign.com

Our experienced team can assist you with product information, installation and design recommendations.