

DreamCast Lotus 32



EFFECTIVE CHOICE

Combining classic with modern. The Lotus 32 fire bowl is beautifully made to make any outdoor space warm and inviting. Complete with a 4" sculpted rim for greater functionality.

Product Features/ Specifications:

- 55K BTU Natural Gas
- 50K BTU Liquid Propane
- Complimentary Lava Rocks
- Other media available for purchase
- Manual Lit Ignition (available for upgrade to Electronic Ignition - please contact for further information)
- Weight: 110 lbs.
- Overhead clearance: 84" - 120" (depending on burner) and 36" horizontally to combustibles.

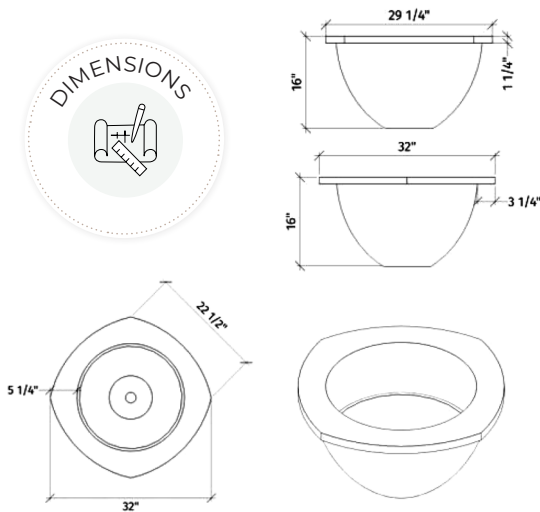
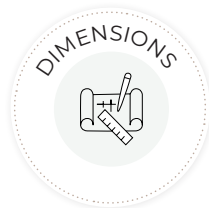

Min. and Max. Gas Inlet Pressures:

The installer is responsible for using the correct fuel lines and/or regulation to provide gas to the fire feature within the specified minimum and maximum gas inlet pressures.

Refer to installation manual for further information

Gas Inlet Pressures

Match Light	Minimum	Maximum
Natural Gas	3.5" W.C. (.8718Kpa)	7.0" W.C. (1.7436Kpa)
Liquid Propane	11.0" W.C. (2.7399 Kpa)	13.0" W.C. (3.2381 Kpa)



DreamCast
Design & Production

Please contact us at **1-604-278-4939** with any questions. We also encourage you to explore our website at www.dreamcastdesign.com

Our experienced team can assist you with product information, installation and design recommendations.

Lotus 32

DreamCast

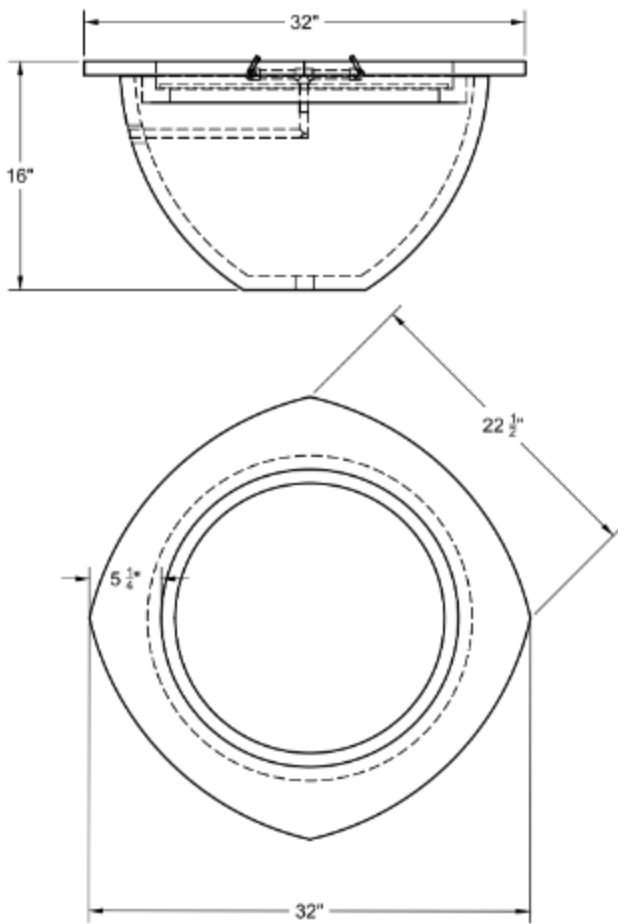

Simplicity at its finest is found with the Lotus32.

The petal shaped rim draws function to the modern bowl design and enables maximum use of space.

DreamCast
Design & Production

Please contact us at [1-604-278-4939](tel:1-604-278-4939) with any questions. We also encourage you to explore our website at www.dreamcastdesign.com

Our experienced team can assist you with product information, installation and design recommendations.