

Linea 72

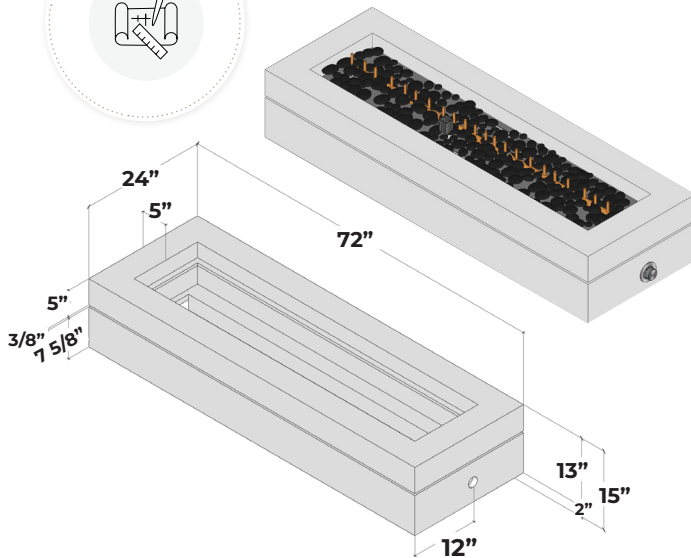
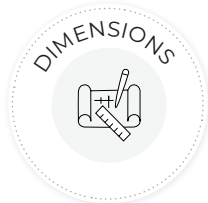

MODERN FLAME

Our **Linea** is a stunning addition to an outdoor living area. Its long line of modern fire creates a stunning visual display and still keeps a comfortable 5" of table space all around. This unit is perfect either for an entertainment space or to create a space divider.

Product Features/ Specifications:

- 275K BTU Natural Gas
- Liquid Propane 245K BTU
- Complimentary Lava Rocks
- Other media available for purchase
- Pilot Lit Ignition (available for upgrade to Electronic Ignition - please contact for further information)
- Weight: 305 lbs.
- Overhead clearance: None + 36" horizontally to combustibles.
- Not compatible w/portable Propane Systems
- Low clearance model available

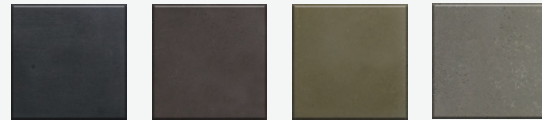

CHARCOAL CHOCOLATE PORTOBELLO HAZE



LONDON FOG MIST MOONLIGHT CHALK



CAPPUCCINO MOCHA

Min. and Max. Gas Inlet Pressures:

The installer is responsible for using the correct fuel lines and/or regulation to provide gas to the fire feature within the specified minimum and maximum gas inlet pressures.

Refer to installation manual for further information

Gas Inlet Pressures

Match Light	Minimum	Maximum
Natural Gas	7.0" W.C. (1.7436 Kpa)	10.0" W.C. (2.4884 Kpa)
Liquid Propane	11.0" W.C. (2.7399 Kpa)	13.0" W.C. (3.2381 Kpa)

Linea 72

DreamCast

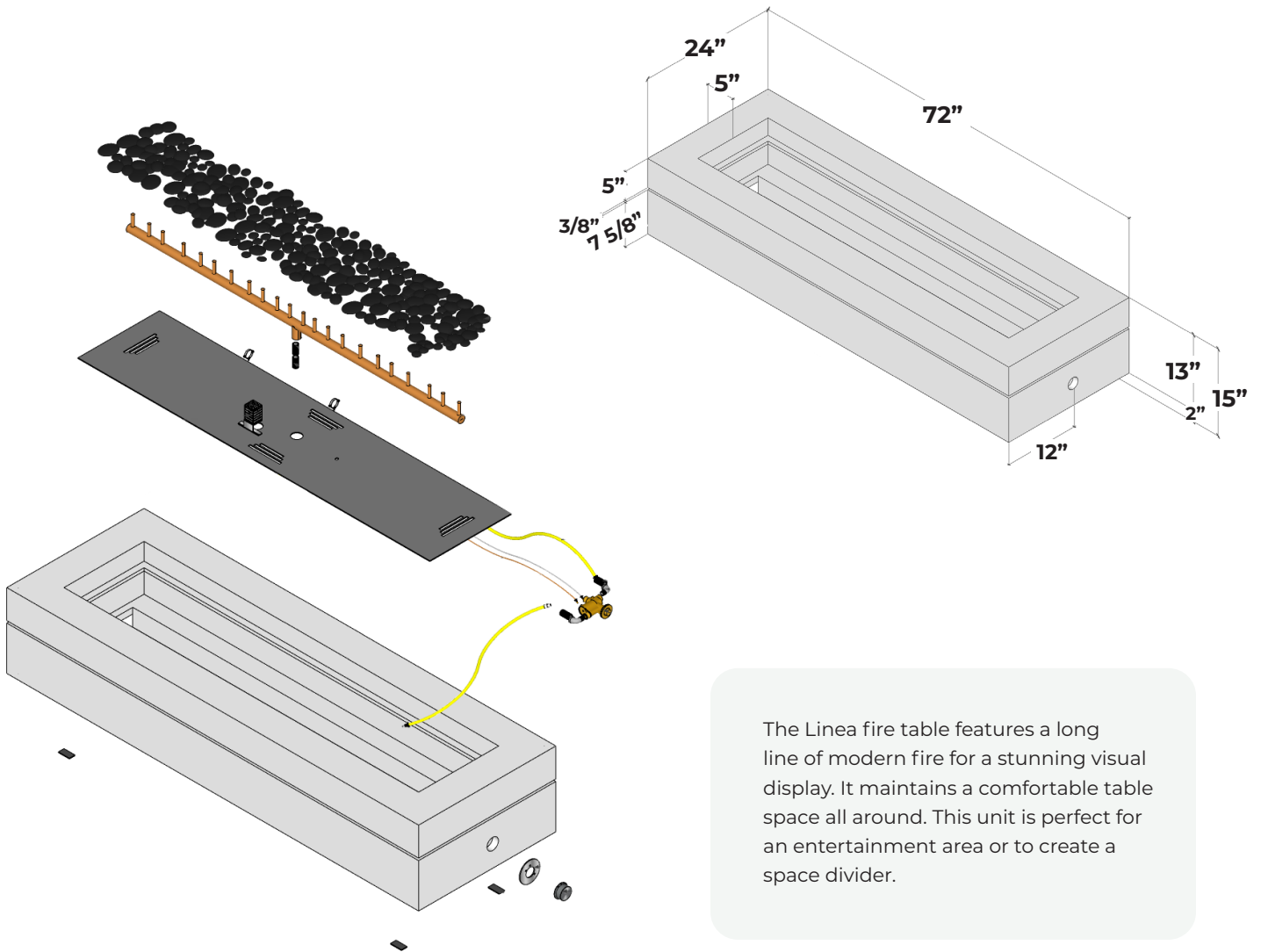

The Linea fire table features a long line of modern fire for a stunning visual display. It maintains a comfortable table space all around. This unit is perfect for an entertainment area or to create a space divider.

DreamCast
Design & Production

Please contact us at **1-604-278-4939** with any questions. We also encourage you to explore our website at www.dreamcastdesign.com

Our experienced team can assist you with product information, installation and design recommendations.