

DreamCast Phantom 48



MINIMALIST DESIGN MAXIMUM FLAME

Our **Phantom** Fire Pit is a stunning addition to any outdoor living area. With the focus entirely on the impressive linear flame, this unit is perfect either for an outdoor entertainment area or to create a space divider.

Product Features/ Specifications:

- 160K BTU
- Liquid Propane and Natural Gas
- Complimentary Lava Rocks
- Other media available for purchase
- Pilot Lit Ignition (available for upgrade to Electronic Ignition - please contact for further information)
- Weight: 155 lbs.
- Overhead clearance: None + 36" horizontally to combustibles.
- Not compatible w/portable Propane Systems
- Low clearance model available

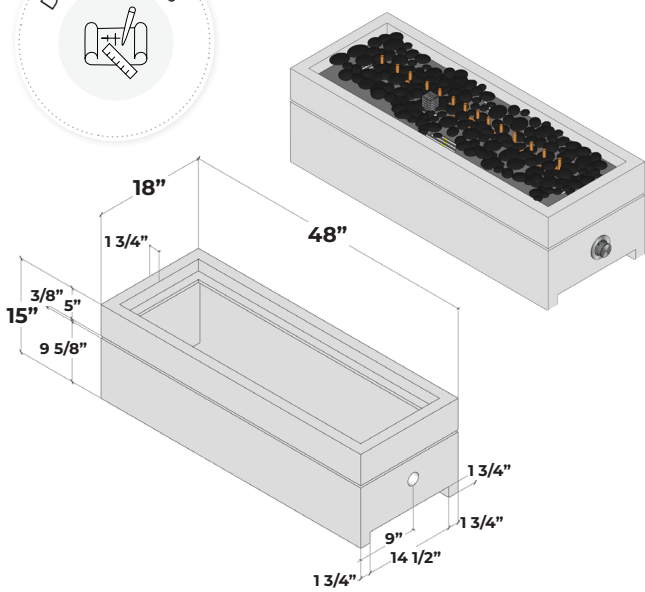
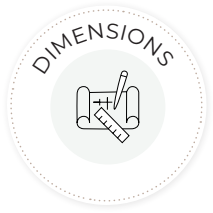

Min. and Max. Gas Inlet Pressures:

The installer is responsible for using the correct fuel lines and/or regulation to provide gas to the fire feature within the specified minimum and maximum gas inlet pressures.

Refer to installation manual for further information

Gas Inlet Pressures

Match Light	Minimum	Maximum
Natural Gas	7.0" W.C. (1.7436 Kpa)	10.0" W.C. (2.4884 Kpa)
Liquid Propane	11.0" W.C. (2.7399 Kpa)	13.0" W.C. (3.2381 Kpa)

Our experienced team can assist you with product information, installation and design recommendations.

Phantom 48

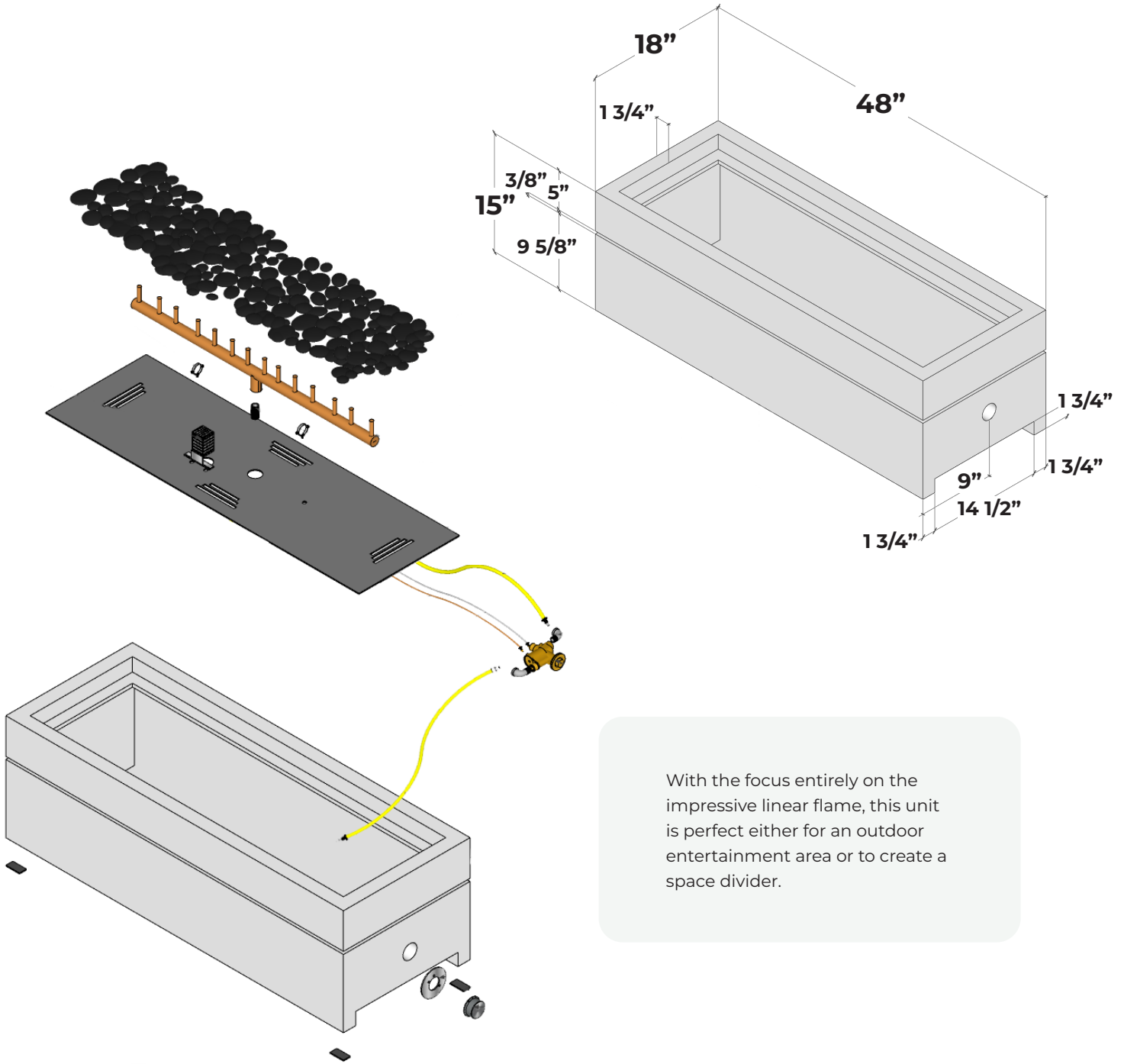

With the focus entirely on the impressive linear flame, this unit is perfect either for an outdoor entertainment area or to create a space divider.

DreamCast
Design & Production

Please contact us at **1-604-278-4939** with any questions. We also encourage you to explore our website at www.dreamcastdesign.com

Our experienced team can assist you with product information, installation and design recommendations.