

# Resort 48

## RELAXED LUXURY

The Resort 48 brings a refined sense of leisure with its elegant proportions and modern finish. Its warm flame sets the stage for effortless gatherings and timeless style.

**Weight** 250 lbs.

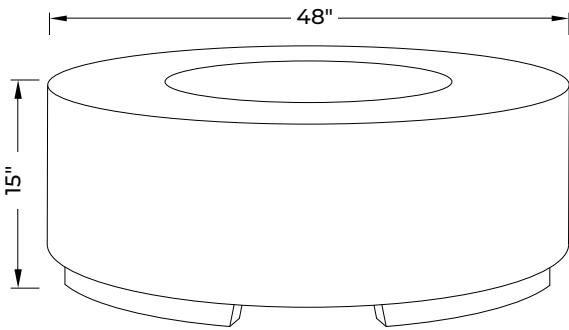

### Dimensions

48" x 15"



WHITE WISP



GREY CLOUD

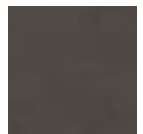

GRAPHITE SKY

## TECHNICAL DATA

### Low-Clearance system

(CSA/UL Approved Burner assembly)

### Manual

65K BTU NG/LP

### Electronic Ignition

100K BTU NG/LP



For technical information, view the manual

[www.dreamcastdesign.com](http://www.dreamcastdesign.com)

**DreamCast**  
Design & Production



Please contact us at 1-888-616-4939 with any questions, or email us at [info@dreamcastdesign.com](mailto:info@dreamcastdesign.com)

# Resort 48

All units ship with either NG/LP burner, lava rock topping and water resistant cover.

## TOPPING OPTIONS



RIVER STONES



TUMBLER ROCKS



LOG SETS

## EI ACCESSORIES



TIMER



REMOTE



EMERGENCY STOP

To explore more toppings & accessories, visit [www.dreamcastdesign.com](http://www.dreamcastdesign.com)

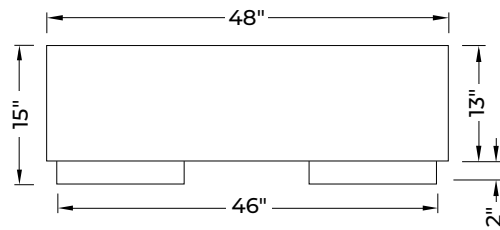
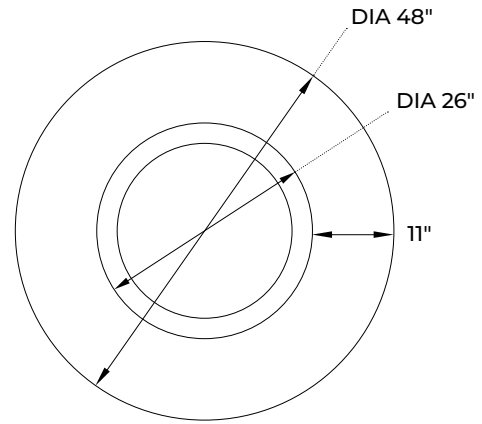

SIDE VIEW - BASE

## Min. and Max. Gas Inlet Pressures

The installer is responsible for using the correct fuel lines and/or regulation to provide gas to the fire feature within the specified minimum and maximum gas inlet pressures.

Refer to installation manual for more details

